



4096-417
REVISION B
FEBRUARY 20, 1998

ASSEMBLY MANUAL

C-BAND Rx/Tx ODU FEED INSTALLATION

PRODELIN CORPORATION
1500 PRODELIN DRIVE
NEWTON, NC 28658
828-464-4141

C-BAND Rx/Tx ODU FEED INSTALLATION

B	Revised Title	2/20/98	
A	ADDED CIRC. POL INSTRUCTIONS	06-22-95	RF
-	ORIGINAL RELEASE	02/10/95	PLG
REV.	DESCRIPTION	DATE	APPROVED

These instructions outline the installation of a C-Band Rx/Tx feed assembly with transmitter on a 1.8M or 2.4M antenna.

Section I outlines installation for a circular polarized system and Section II outlines installation for a linear polarized system (INSAT or standard frequency).

SECTION I

CIRCULAR FEED SUPPORT BRACKET INSTALLATION

Refer to the following table for item and part numbers used in these steps:

STEP 1: Attach the bottom feed mounting bracket (item# 2) and ODU support bracket (item 1) to the feed support arm with [4] 3/8-16 x 1.25" bolts, [4] lockwashers, and [4] 3/8-16 hex nuts (items 5,7,8), as shown in figure 1. Attach lower end of bracket to feed support with 5/16-18 x 3.25" bolt, [2] flatwashers, lockwashers, and 5/16-18 hex nut (items 9,10,11,12). Tighten securely.

STEP 2: Attach the disc mounting angle (item# 3) to ODU support bracket with 3/8 x 1.00 bolts, flat washers, lock washers, and nuts (item# 4,6,7,8). Leave loose to allow for adjustment.

STEP 3: Attach the second bottom feed mounting bracket (item 2) to the ODU support bracket with [4] 3/8-16 x 1.00" bolts, [4] lock washers, and [4] 3/8-16 hex nuts (items 7,8,13) in the location and orientation shown. Leave loose to allow for adjustment.

PARTS LIST - CIRCULAR FEED, SUPPORT BRACKET INSTALLATION			
ITEM #	PART #	DESCRIPTION	QUANTITY
1	0181-714	BRACKET, ODU SUPPORT (1.8M)	1
1	0181-720	BRACKET, ODU SUPPORT (2.4M)	1
2	0211-420	FEED MOUNTING BRACKET	2
3	0225-601	ANGLE, DISC MOUNTING	1
4	8032-008	3/8-16 X 1.00" BOLT	6
5	8032-010	3/8-16 X 1.25" BOLT	4
6	8201-042	3/8" FLATWASHER	4
7	8202-042	3/8" LOCKWASHER	10
8	8102-007	3/8-16 HEX NUT	10
9	8031-026	5/16-18 X 3.25" BOLT	1
10	8201-041	5/16" FLATWASHER	2
11	8202-041	5/16" LOCKWASHER	1
12	8101-009	5/16-18 HEX NUT	1

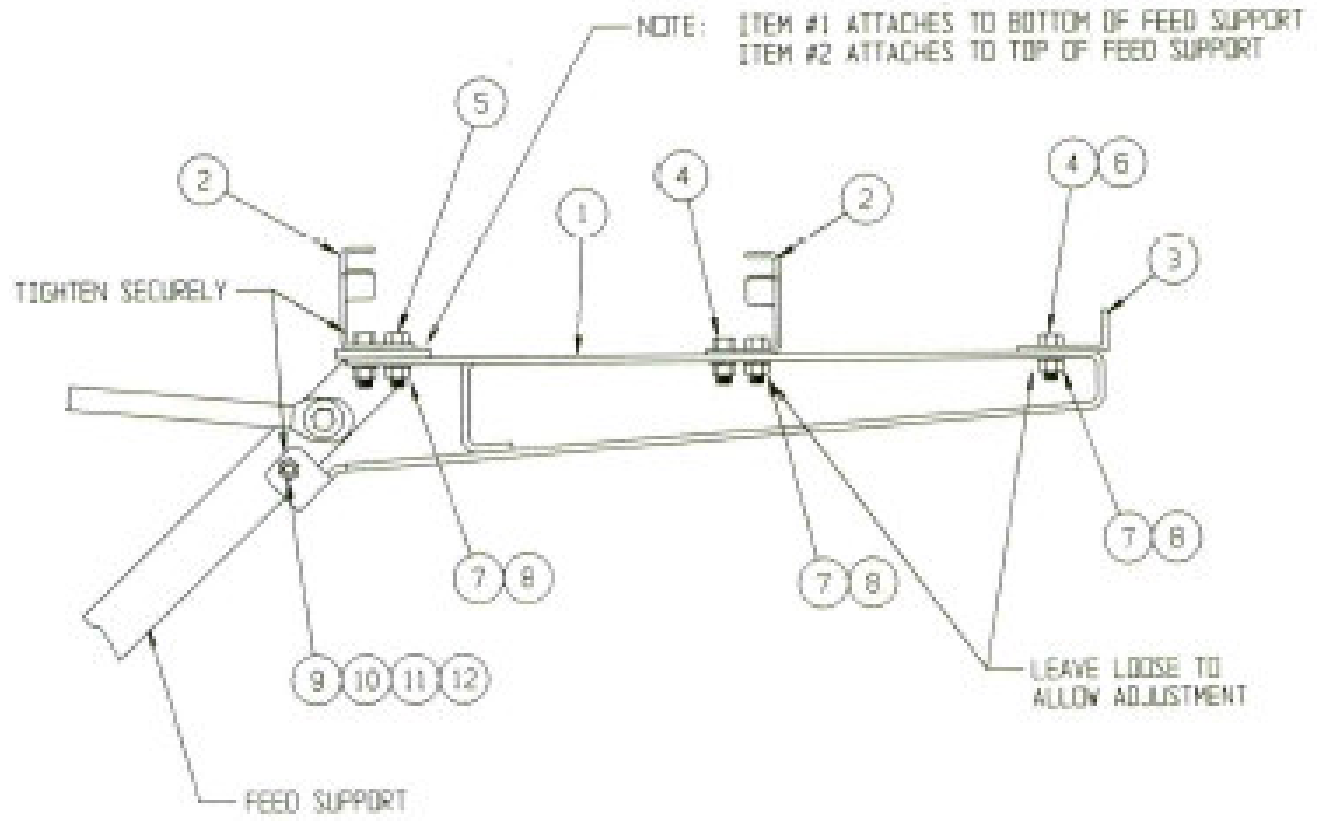

FIGURE 1

CIRCULAR FEED ASSEMBLY AND INSTALLATION

Refer to the following table for item and part numbers for these steps.

- STEP 1:** Assemble the ODU to the Tx port of the feed assembly (item #1) with the disc and spacer, as shown in figure 2. Place the gasket (supplied with ODU) between the feed and ODU flanges. Use the 2 short #10 screws (item# 4) in the top 2 holes, and the 6 long #10 screws (item #5) through the disc and spacer. Use lockwasher and flatwashers (item #6,7) as shown. Tighten securely.
- STEP 2:** Attach LNB to OMT with 1/4-20 x 1.00" screws, flatwashers, lockwashers and nuts (item# 8,9,10,11). Tighten securely.
- STEP 3:** Place the completed feed assembly on the support bracket, with the neck of the feed horn in the front feed mounting bracket, the back of the polarizer in the back feed mounting brackets, and the disc on the inside of the angle. Secure with the top feed mounting bracket (item 12) using [2] 5/16-18 x 1.00" bolts, [2] lockwashers, and [2] 5/16-18 hex nuts (items 14,16,17) at the feed horn, and [2] 5/16-18 x 1.50" bolts, [2] lockwashers, and [2] 5/16-18 x hex nuts (items 18,16,17) at the polarizer.
- STEP 4:** Slide the angle against the radio mounting disc. Tighten the 3/8" hardware to prevent sliding. Install the 5/16-18 x .75" bolts, flatwashers and lockwashers (item# 13,15,16) from the inside of the angle. Tighten all feed mounting hardware securely.

PARTS LIST - CIRCULAR FEED ASSEMBLY AND INSTALLATION			
ITEM #	PART #	DESCRIPTION	QUANTITY
1	VARIES	FEED ASSEMBLY, CIRCULAR	1
2	0211-625	DISC, ODU MOUNTING	1
3	0159-267	SPACER, ODU MOUNTING	1
4	8302-005	SCREW, 10-32 X .75"	2
5	8302-014	SCREW, 10-32 X 1.00"	6
6	8201-037	#10 FLATWASHER	8
7	8202-032	#10 LOCKWASHER	8
8	8023-008	1/4-20 X 1.00" BOLT	10
9	8201-036	1/4 FLATWASHER	20
10	8202-031	1/4 LOCKWASHER	10
11	8100-005	1/4 NUT	10
12	0211-419	BRACKET, TOP, FEED MTG	2
13	8031-006	5/16-18 X .75" BOLT	2
14	8031-008	5/16-18 X 1.00" BOLT	2
15	8201-041	5/16 FLATWASHER	2
16	8202-041	5/16 LOCKWASHER	6
17	8101-009	5/16 NUT	4
18	8031-012	5/16-18 X 1.50"	2

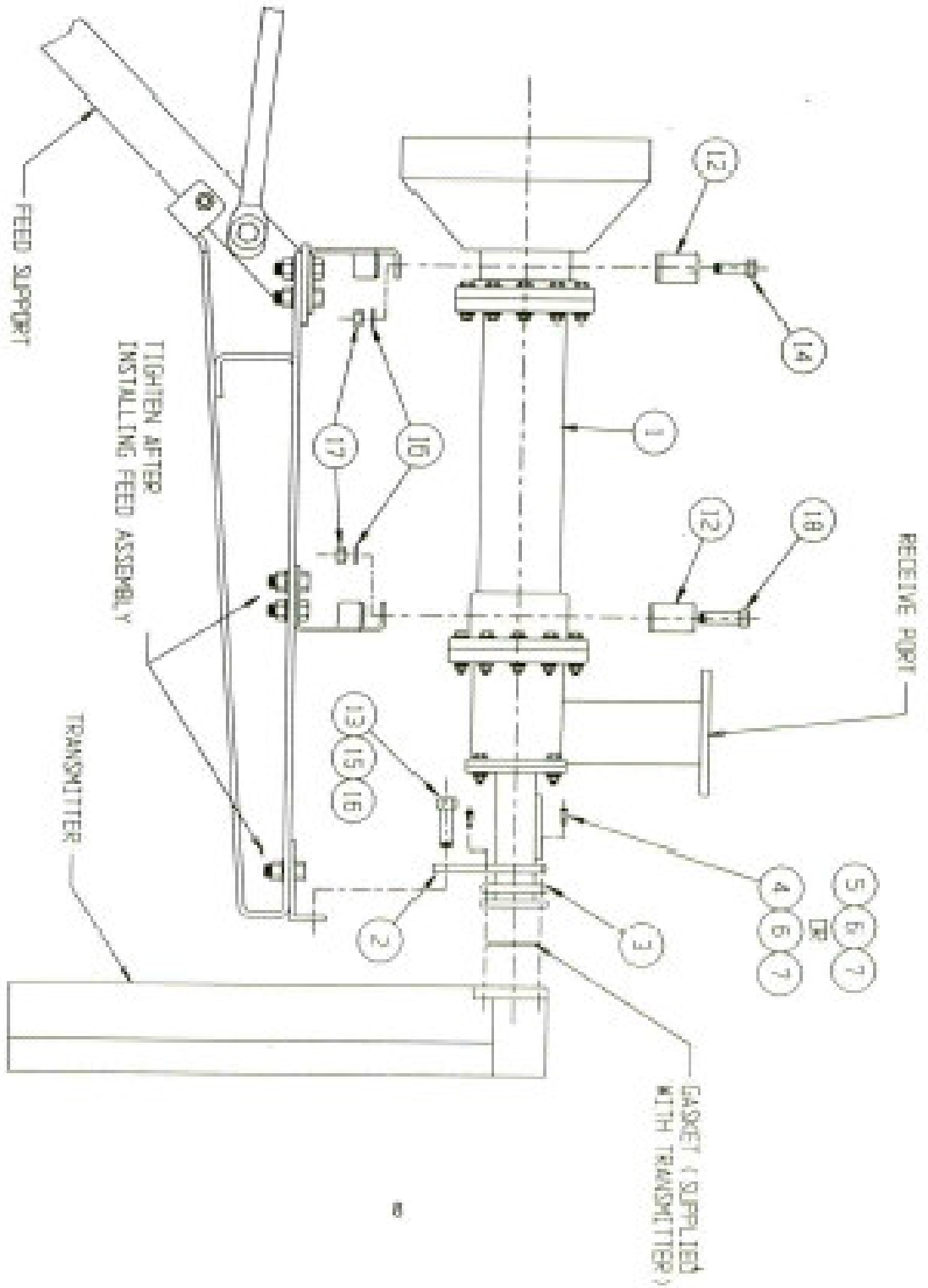

FIGURE 2

SECTION II**LINEAR FEED SUPPORT BRACKET INSTALLATION**

Refer to the following table for item and part numbers used in these steps:

STEP 1: Attach the bottom feed mounting bracket (item #2) and ODU support plate (item 1) to the feed support arm with [4] 3/8-16 x 1.25" bolts, [4] lockwashers, and [4] 3/8-16 hex nuts (item# 5,7,8), as shown in figure 1. Tighten securely. ***NOTE: For Insat installations, use the back set of holes and for standard c-band , use the front set as shown in figure 3.***

STEP 2: Attach the disc mounting angle (item# 3) to ODU support plate with 3/8 x 1.00 bolts, flatwashers, lockwashers, and nuts (item# 4,6,7,8). Leave loose to allow for adjustment.

PARTS LIST - INSAT LINEAR FEED, SUPPORT BRACKET INSTALLATION			
ITEM #	PART #	DESCRIPTION	QUANTITY
1	0156-125	PLATE, ODU SUPPORT	1
2	0211-420	FEED MOUNTING BRACKET	1
3	0225-601	ANGLE, DISC MOUNTING	1
4	8032-008	3/8-16 X 1.00" BOLT	2
5	8032-010	3/8-16 X 1.25" BOLT	4
6	8201-042	3/8" FLATWASHER	4
7	8202-042	3/8" LOCKWASHER	6
8	8102-007	3/8-16 HEX NUT	6

PARTS LIST - LINEAR FEED ASSEMBLY AND INSTALLATION			
ITEM #	PART #	DESCRIPTION	QUANTITY
1	VARIES	FEED ASSEMBLY, LINEAR	1
2	0211-625	DISC, ODU MOUNTING	1
3	0159-267	SPACER, ODU MOUNTING	1
4	8302-005	SCREW, 10-32 X .75'	2
5	8302-014	SCREW, 10-32 x 1.00"	6
6	8201-037	#10 FLATWASHER	8
7	8202-032	#10 LOCKWASHER	8
8	8023-008	1/4-20 X 1.00" BOLT	10
9	8201-036	1/4 FLATWASEHR	20
10	8202-031	1/4 LOCKWASHER	10
11	8100-005	1/4 NUT	10
12	0211-419	BRACKET, TOP, FEED MTG	1
13	8031-006	5/16-18 X .75" BOLT	2
14	8031-008	5/16-18 X 1.00" BOLT	2
15	8201-041	5/16 FLATWASHER	2
16	8202-041	5/16 LOCKWASHER	4
17	8101-009	5/16 NUT	2

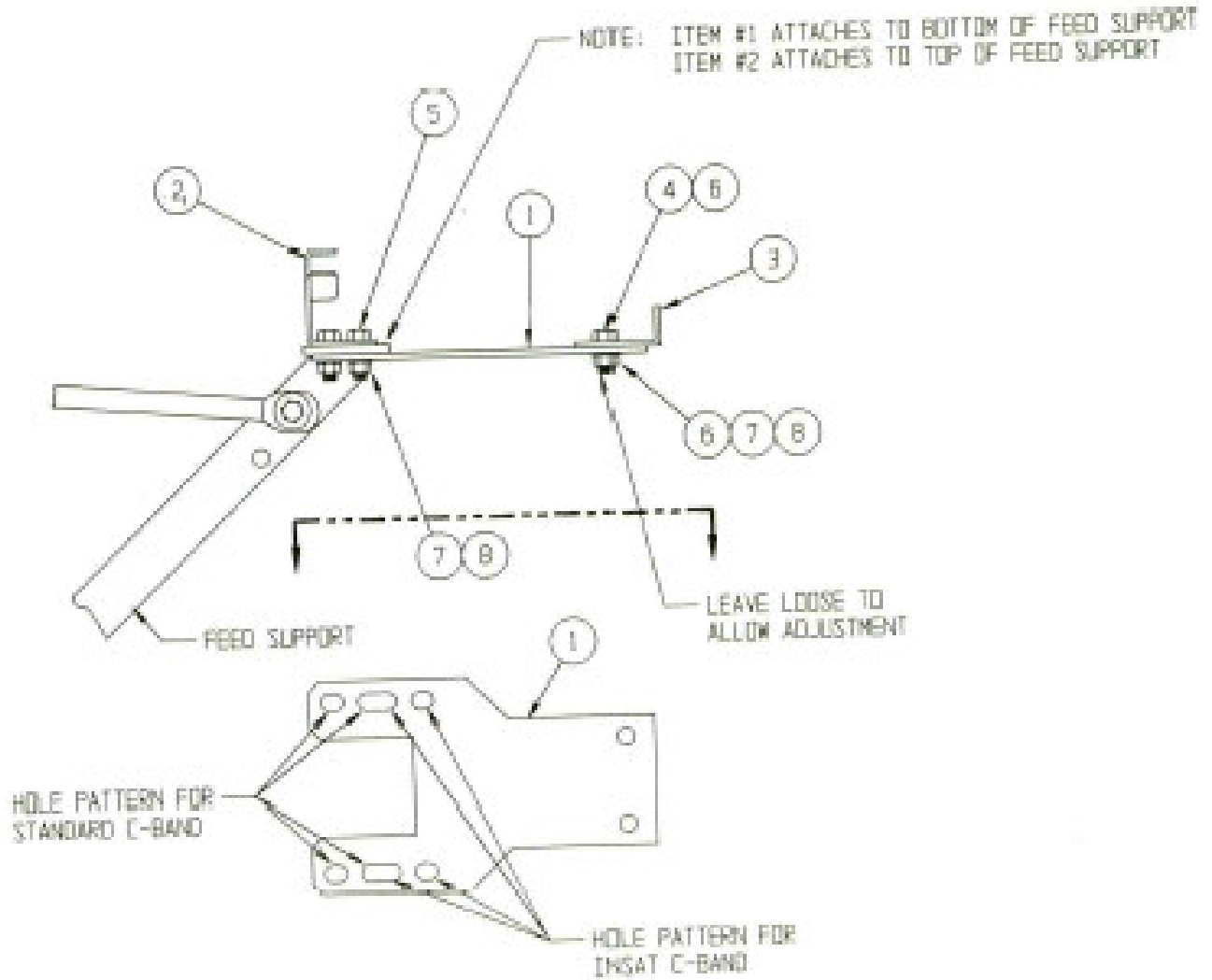

FIGURE 3

LINEAR FEED ASSEMBLY AND INSTALLATION

Refer to the following table for item and part numbers for these steps.

- STEP 1:** Assemble the ODU to the Tx port of the feed assembly (item #1) with the disc and spacer, as shown in figure 4. Place the gasket (supplied with ODU between the feed and ODU flanges. Use the 2 short #10 screws (item #4) in the top 2 holes, and the 6 long #10 screws (item #5) through the disc and spacer. Use lockwashers and flatwashers (item #6,7) as shown. Tighten securely.
- STEP 2:** Attach LNB to OMT with 1/4-20 x 1.00" screws, flatwashers, lockwashers and nuts (item# 8,9,10,11). Tighten securely.
- STEP 3:** Place the completed feed assembly on the support bracket, with the neck of the feed horn in the feed mounting bracket, and the disc on the inside of the angle. Secure with the top feed mounting bracket (item # 12) using [2] 5/16-18 x 1.00" bolts, [2] lockwashers, and [2] 5/16-18 hex nuts (item # 14, 16,17).
- STEP 4:** Slide the angle against the radio mounting disc. Tighten the 3/8" hardware to prevent sliding. Install the 5/16-18 x .75" bolts, flatwashers and lockwashers (item# 13,15,16) from the inside of the angle. Tighten securely after desired polarization is achieved.

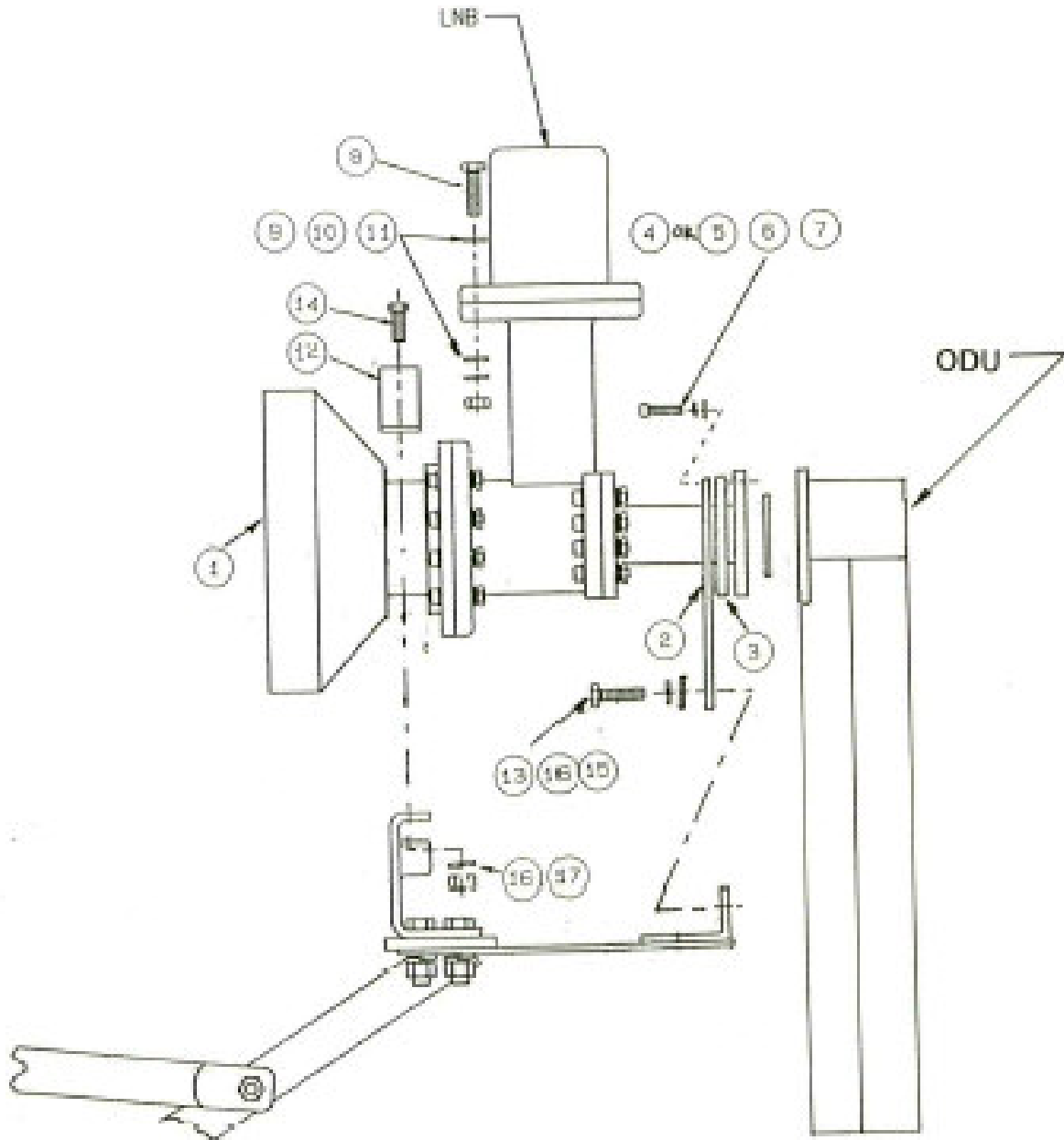

FIGURE 4