



PRODELIN™
A TriPoint Global Company

4096-364

January 11, 2002
Revision D

ASSEMBLY MANUAL

10' X 10' NPMM Installation

PRODELIN CORPORATION
1500 Prodelin Drive
Newton NC 28658

**10' x 10' NPMM
INSTALLATION INSTRUCTIONS**

D	Added 5.56" OD Mast Option	03/12/04	R.F.
C	Revised Address	1/11/02	RAH
B	Revise Rubber Pad	6/14/00	RAH
A	Added Metric Tables	9/26/97	PGW
-	ORIGINAL RELEASE	8/26/94	RF
REV.	DESCRIPTION	DATE	APPROVED

ASSEMBLY MANUAL

NON-PENETRATING MAST MOUNT

TABLE OF CONTENTS

<u>SECTION</u>	<u>TITLE</u>
I	GENERAL INFORMATION
1.0	GENERAL INFORMATION
1.1	UNPACKING & INSPECTION
1.2	SUGGESTED TOOL LIST
1.3	PARTS LIST – (4.00” OD Mast)
1.4	PARTS LIST – (5.56” OD Mast)
II	ASSEMBLY INSTRUCTIONS
2.0	ASSEMBLY INSTRUCTIONS
III	BALLAST REQUIREMENTS
3.0	BALLAST REQUIREMENTS TABLE
3.1	BALLAST REQUIREMENTS INFORMATION

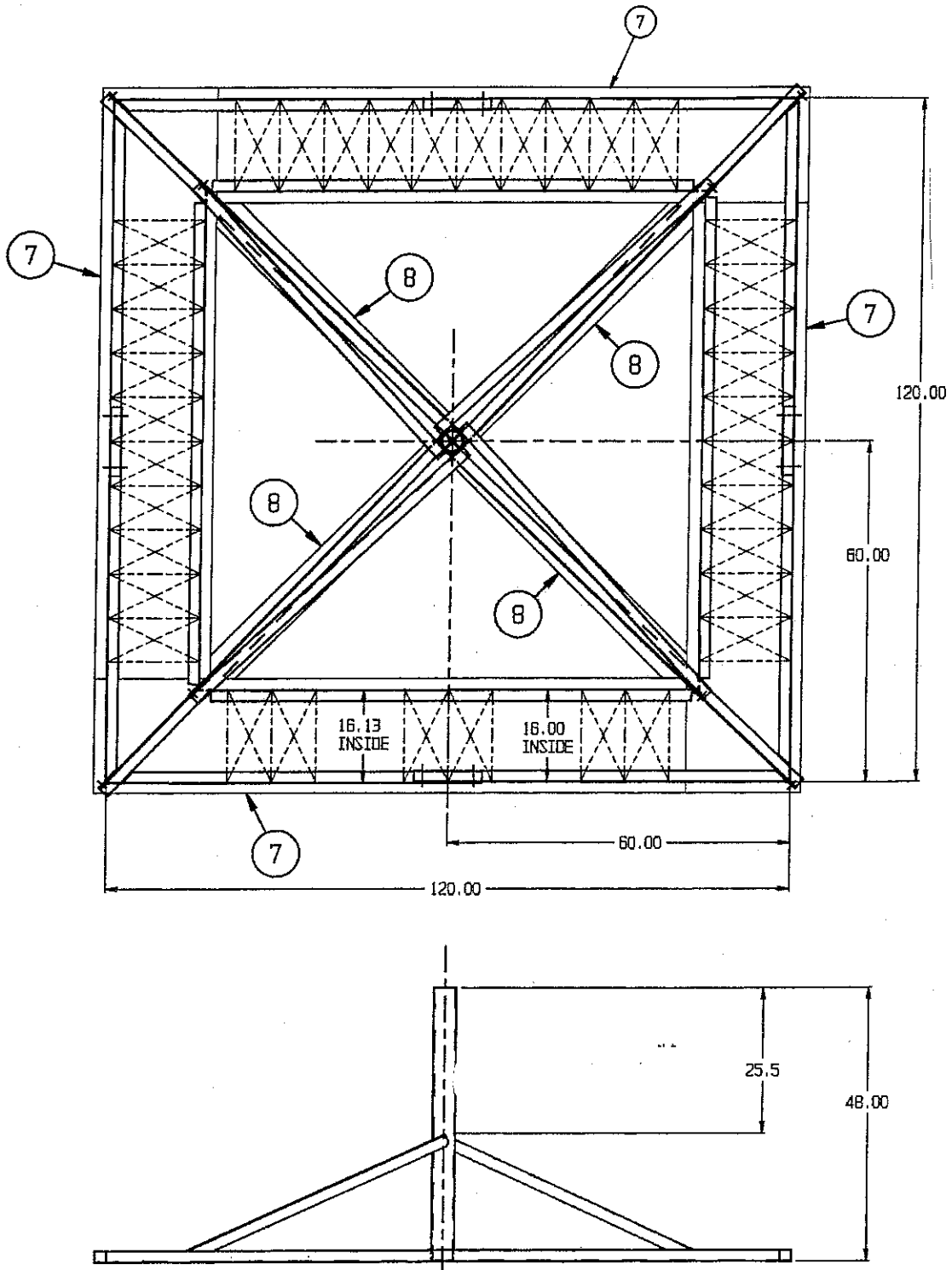

Figure 1

SECTION I

1.0 GENERAL INFORMATION

1. Prior to installation, verify that the installation site roof material and supporting structure have been investigated and found capable of withstanding all loads imposed by the proposed antenna system. Confirm that the supporting surfaces, anchors, and/or safety cables, if required, have been found to be adequate to resist the reactions from the antenna system and that the installation will be in accordance with all applicable local, state, and federal requirements.
2. All antenna installations should be grounded to meet all applicable codes.
3. Rubber pads are provided to protect the roof surface.
4. All necessary hardware is provided.
5. For assistance in determining ballast requirements refer to chart in section 3.
6. All metal parts are of galvanized construction to help prevent corrosion.

1.1 UNPACKING & INSPECTION

1. UNPACKING & INSPECTING

The mount should be unpacked and inspected at the earliest date to ensure that all material has been received and is in good condition. A complete packing list for each major component is supplied.

2. FREIGHT DAMAGE

Any damage to materials while in transit should be immediately directed to the freight carrier. He will instruct you on the matters regarding any freight damage claims.

3. MATERIAL - MISSING OR DAMAGED

Any questions regarding missing or damaged materials that is not due to freight carrier should be directed to Prodelin's Customer Service Department at:

**PRODELIN CORPORATION
1500 Prodelin Drive
Newton NC 28658
USA
(828) 464-4141**

1.2 SUGGESTED TOOL LIST

1. SITE PREPARATION TOOLS

The following tools are suggested for site preparation.

1. Shovel (for ground installation)
2. Broom

2. SUGGESTED TOOL LIST

The following tools are suggested for the NPMM installation.

1. Ratchet
2. Socket, 9/16" & 3/4"
3. Wrench, combination 9/16" & 3/4"
4. Tape measure

1.3 PARTS LIST – (For 4.00" OD Mast Pipe Option)

PARTS LIST			
ITEM	PART NO.	DESCRIPTION	QTY
1	0184-182	MAST PIPE – 4.00" OD	1
2	0225-545	OUTER BASE ANGLE - TYPE A	4
3	0225-546	OUTER BASE ANGLE - TYPE B	4
4	0225-547	INNER BASE ANGLE	4
5	0225-548	DIAGONAL BASE ANGLE	4
6	0225-549	MAST BRACE ANGLE	4
7	5003-018	18" x 102" PAD	4
8	5003-032	65" x 6" PAD	4
9	8039-012	3/8-16 x 1.50"	16
10	8201-042	3/8" FLATWASHER	16
11	8202-042	3/8" LOCKWASHERR	16
12	8102-007	3/8"-16 HEX NUT	16
13	8033-040	1/2-13 x 5.00"	4
14	8201-043	1/2" FLATWASHER	8
15	8202-043	1/2" LOCKWASHER	4
16	8104-007	1/2-13 HEX NUT	4

1.4 PARTS LIST – (For 5.56" OD Mast Pipe Option)

PARTS LIST			
ITEM	PART NO.	DESCRIPTION	QTY
1	0184-249	MAST PIPE – 5.56" OD	1
2	0225-545	OUTER BASE ANGLE - TYPE A	4
3	0225-546	OUTER BASE ANGLE - TYPE B	4
4	0225-547	INNER BASE ANGLE	4
5	0225-548	DIAGONAL BASE ANGLE	4
6	0225-549	MAST BRACE ANGLE	4
7	5003-018	18" x 102" PAD	4
8	5003-032	65" x 6" PAD	4
9	8039-012	3/8-16 x 1.50"	16
10	8201-042	3/8" FLATWASHER	16
11	8202-042	3/8" LOCKWASHER	16
12	8102-007	3/8"-16 HEX NUT	16
13	666-112-1-602	1/2-13 x 7.00"	4
14	8201-043	1/2" FLATWASHER	8
15	8202-043	1/2" LOCKWASHER	4
16	685-528-5-632	1/2-13 HEX NUT	4

2.0 ASSEMBLY INSTRUCTIONS

- STEP 1: Locate site of installation and clear an area of 10.5 x 10.5 square feet of all debris.
- STEP 2: Place rubber pads (item 6) on cleared area to form a square with (4) small pads (item 7) placed diagonally across center. (See Figure 1)
- STEP 3: Attach an outer base angle - Type A (item #2) to an outer base angle - type B (item #3) by overlapping the ends of the two angles as shown in Figure 2 and securing with (2) 3/8" X 1.50" carriage bolts, flatwashers, lockwashers, and hex nuts (items 9,10,11, &12). Tighten securely. Repeat for the remaining parts so that there are 4 assembled outer angle.
- STEP 4: Layout the (4) outer base angles (assembled in step 3) and the (4) diagonal base angles (item #5) as shown in Figure 3. Attach the outer corners as shown using a 3/8" carriage bolt, flatwasher, lockwasher, and hex nut (items 9, 10, 11, & 12). Snug only.
- STEP 5: Place the mast pipe (item 1) at the center of the diagonal braces as shown in Figure 4 and secure with (2) 1/2" bolts, (4) flatwasher, (2) lockwasher, and (2) hex nuts (items 13, 14, 15, & 16). Snug only. **(Note: Insure small rubber pads are centered under mast)**
- STEP 6: Attach the (4) mast brace angles (item 6) to the mast pipe with (2) 1/2" X 5.00" bolts, (4) flatwashers, (2) lockwashers, and (2) hex nuts (items 13, 14, 15, & 16). Each brace must attach to the side of the mast pipe opposite its diagonal brace angle as shown in Figure 5. Snug only.
- STEP 7: Position the (4) inner brace angles (item 4) as shown in Figure 6 and secure to the mast brace angle and diagonal base angle with a 3/8" carriage bolt, flatwasher, lockwasher, and hex nut (item 9, 10, 11, & 12).
- STEP 8: Tighten all hardware. Recommended torque is 20 ft-lbs dry or 15 ft-lbs lubricated for the 3/8" hardware and 45 ft/lbs dry or 30 ft /lbs lubricated for the 1/2" hardware.
- STEP 9: Add ballast and then install antenna system. See section 3 for ballast requirements.

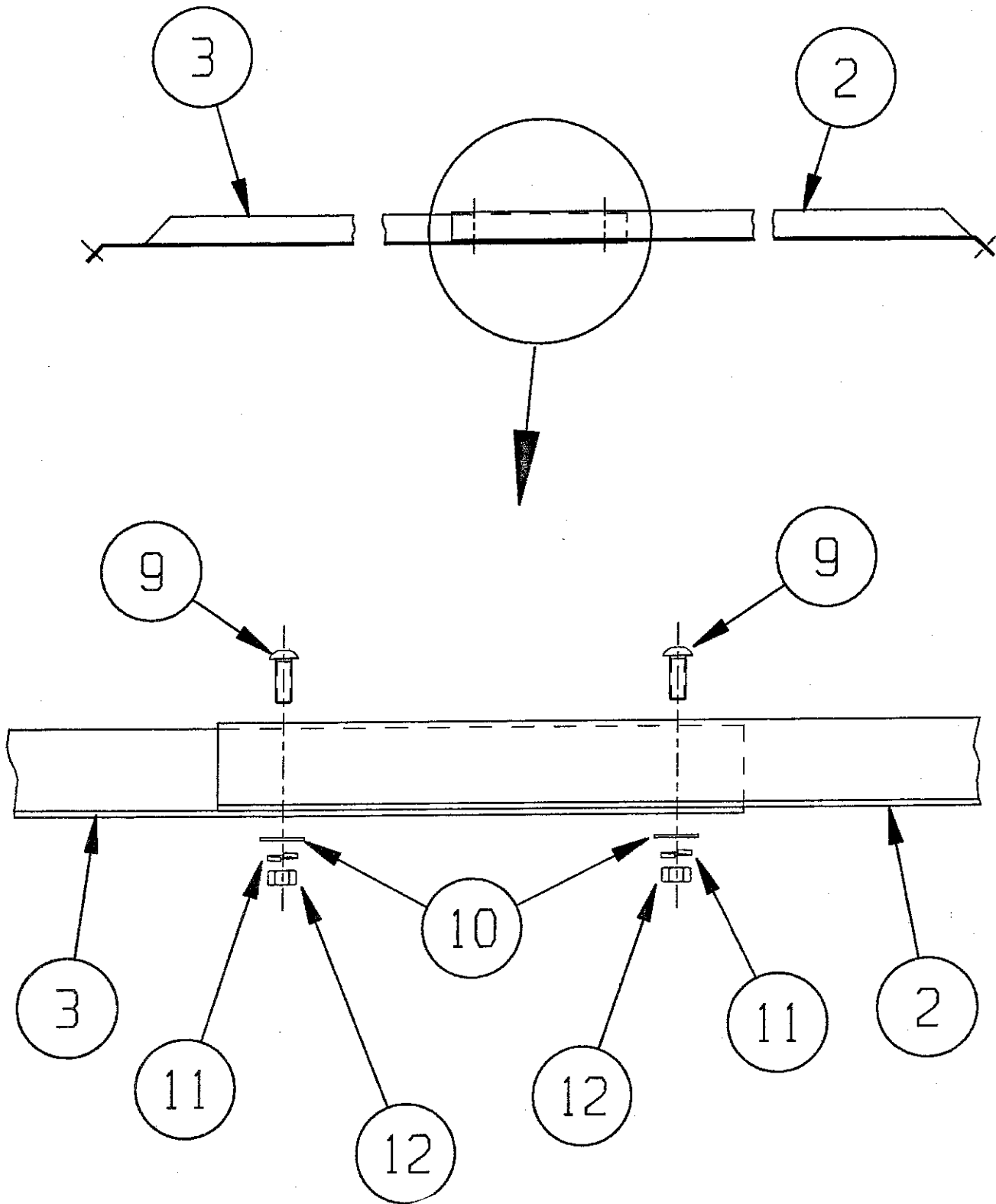

Figure 2

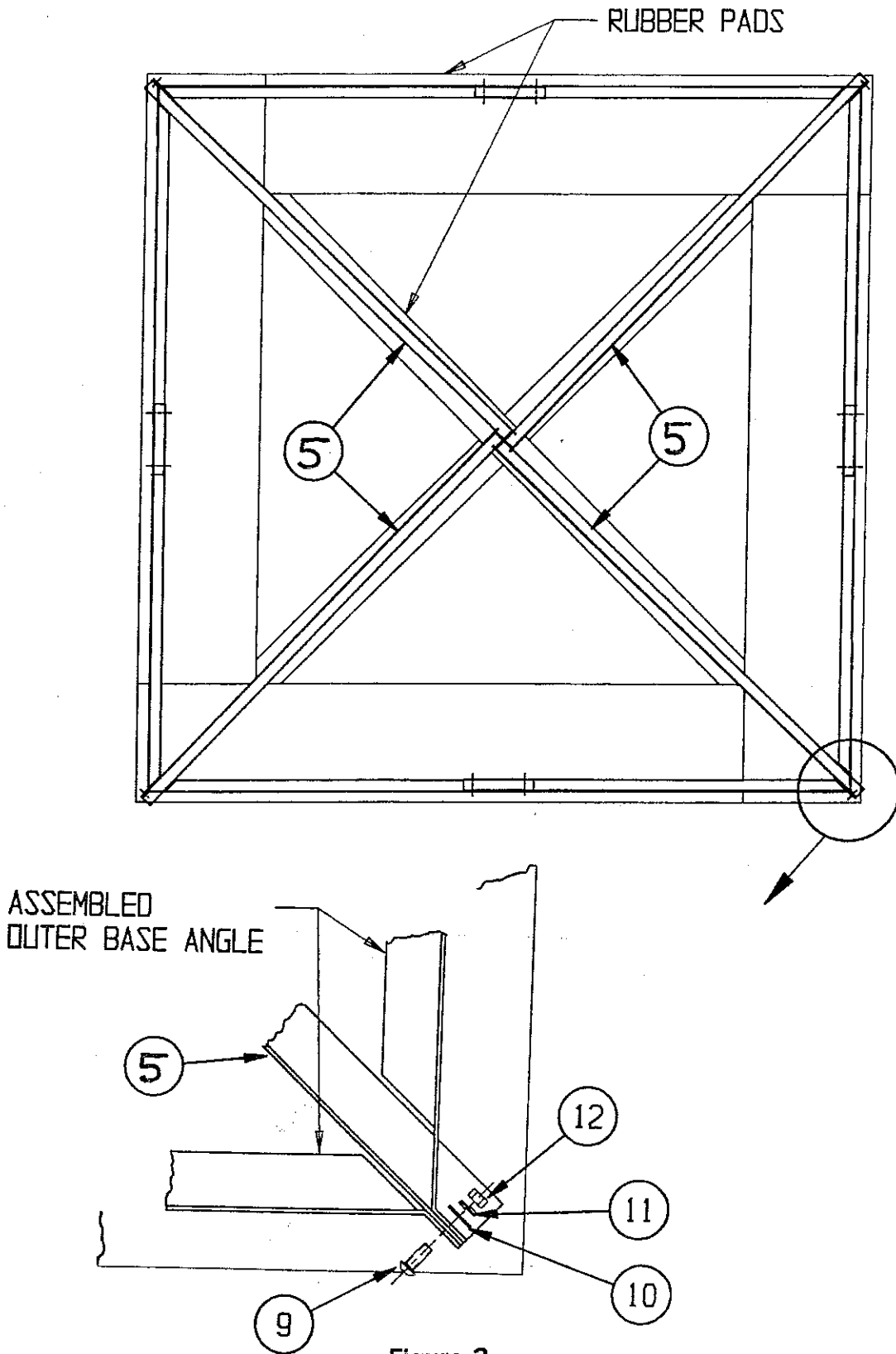

Figure 3

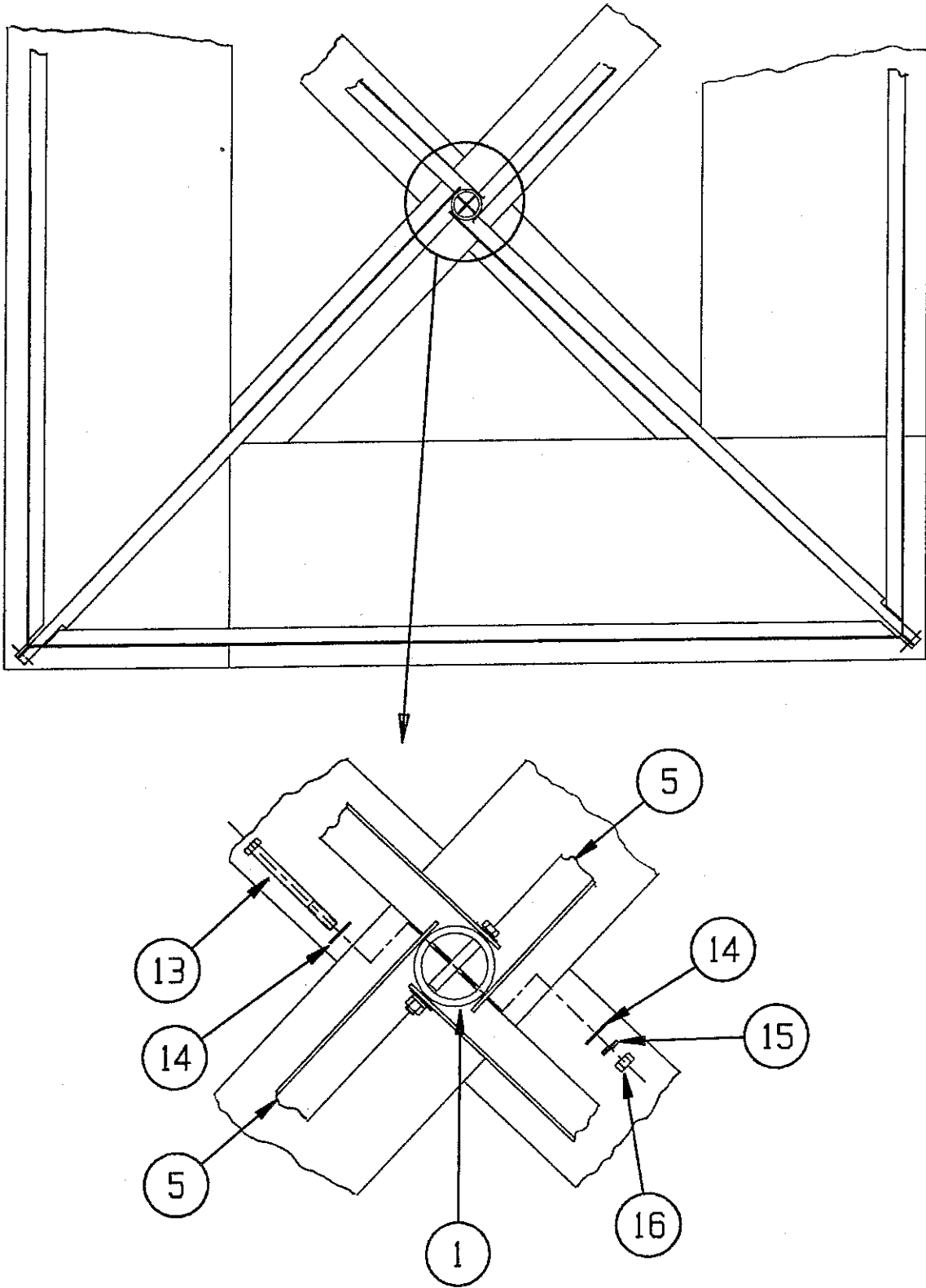

Figure 4

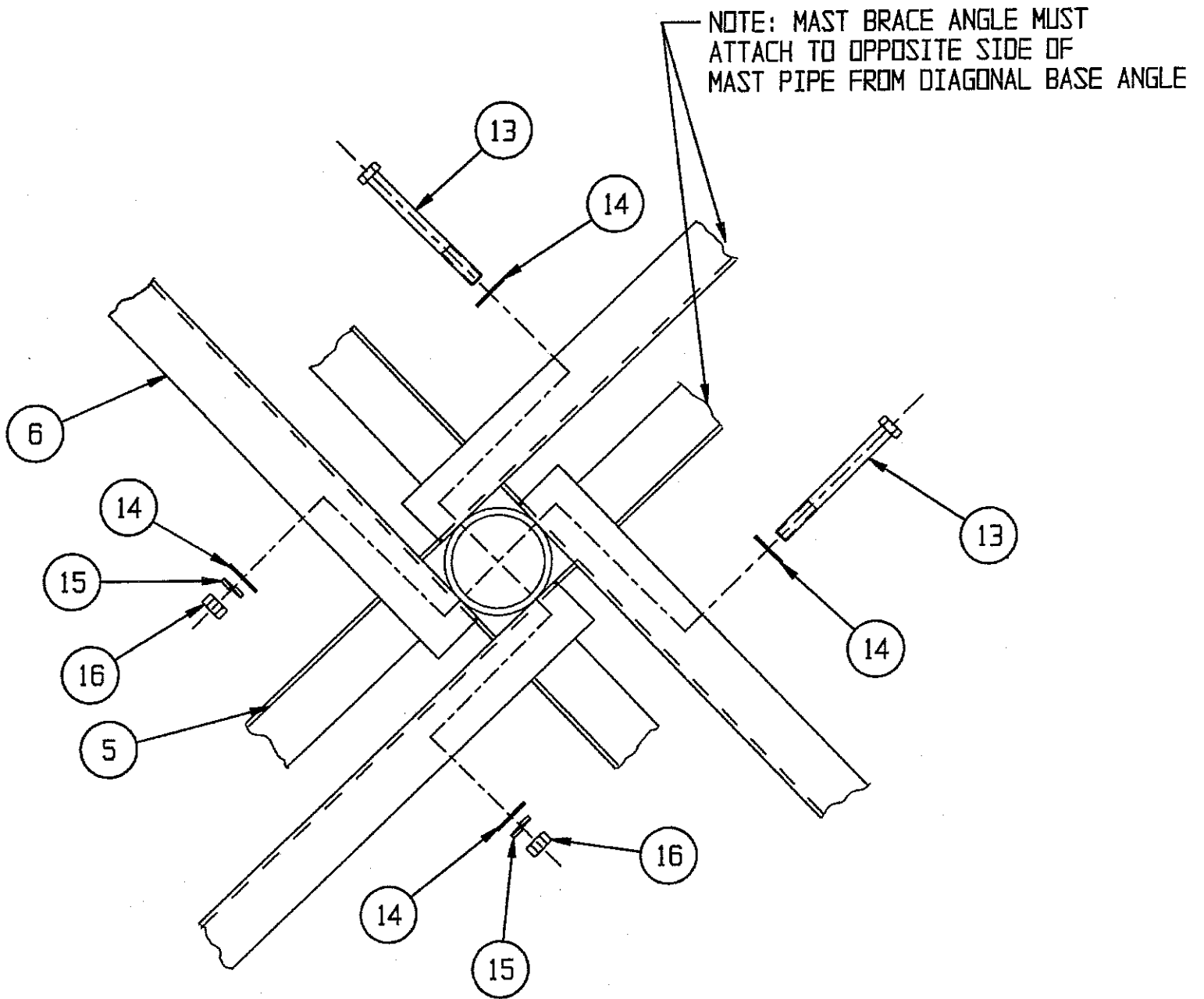

Figure 5

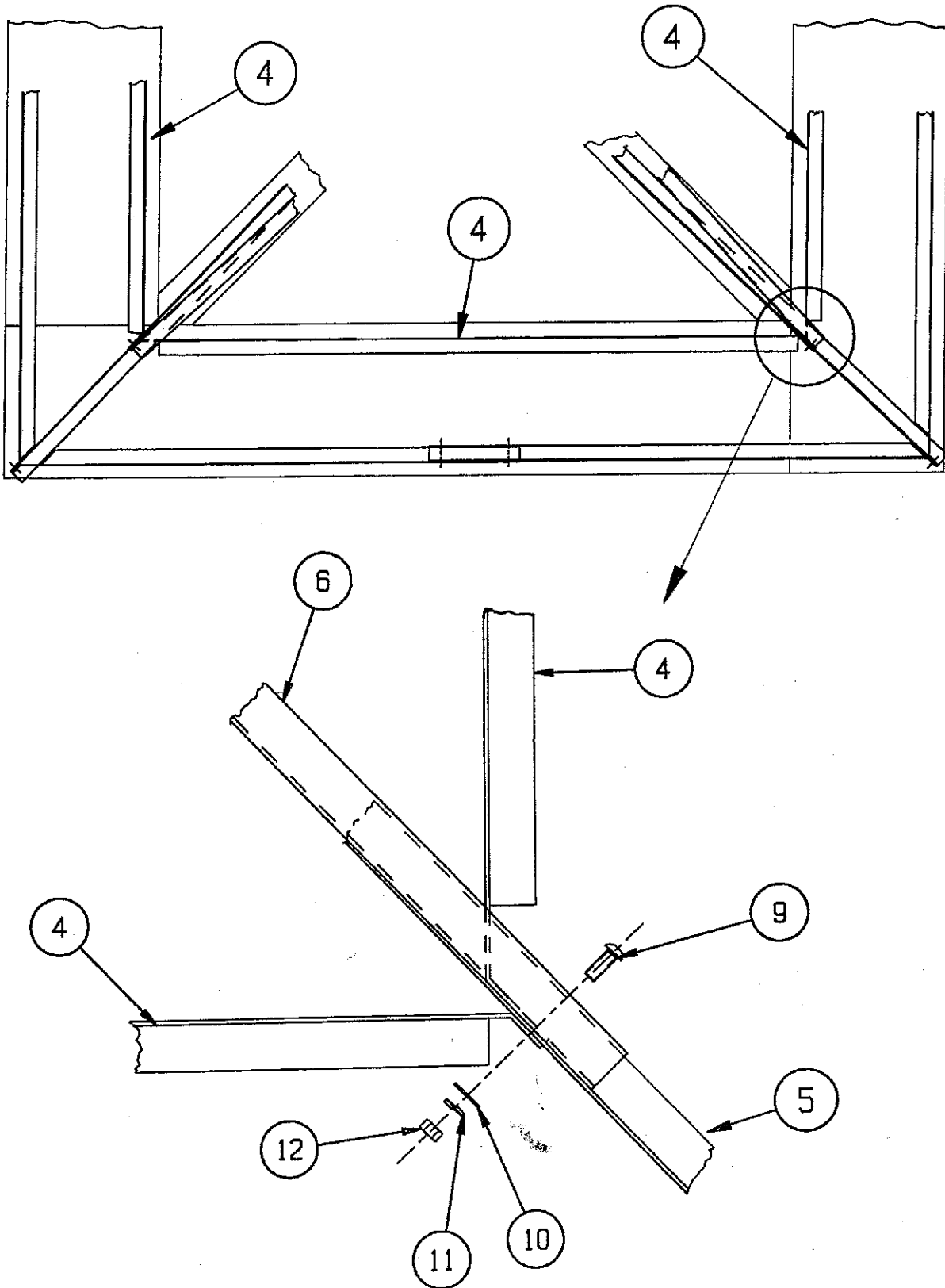

Figure 6

SECTION III

3.0 BALLAST REQUIREMENTS

EXPOSURE:

1. Exposure B is urban or suburban areas, wooded areas, or other terrain with numerous, closely spaced obstructions having the size of single family dwellings or larger. Obstructions must extend 1500 feet in all directions from the antenna.
2. Exposure C is open terrain with widely scattered obstructions having heights generally less than 30 feet. Includes flat open country and grass lands.

BALLAST:

1. Ballast tables are based on an overturning design with a 1.5 safety factor. Values shown provide sliding resistance to the wind speed shown with a 1.0 safety factor when used with a rubber friction pad (coefficient of friction = .64).
2. Recommended ballast material is concrete cap block, nominal dimensions of 4 x 8 x 16 inches. These blocks will weigh between 25 and 30 lbs each, depending on local variation. Average weight of blocks should be determined for correct ballast amount.
3. Place ballast equally on all frames beginning at opposite corners of each side and working inward. If more than 40 blocks are needed, begin a second layer on top of the first.

TABLE 3.0-1 - 1.8M CIRCULAR VSAT ANTENNA
BALLAST REQUIREMENTS - EXPOSURE B - 30 FT. ABOVE GROUND

WIND SPEED (M.P.H.)	70	80	90	100	110	125
TOTAL BALLAST (LBS.)	755	930	1155	1430	1730	2255
STATIC ROOF LOAD (LB./FT ²)	7.6	9.3	11.6	14.3	17.3	22.6
ANTENNA & NPMM WT. (LBS.)	430	430	430	430	430	430
NET BALLAST REQUIRED (LBS.)	325	500	725	1000	1300	1825

TABLE 3.0-2 - 1.8M CIRCULAR VSAT ANTENNA
BALLAST REQUIREMENTS - EXPOSURE B - 50 FT. ABOVE GROUND

WIND SPEED (M.P.H.)	70	80	90	100	110	125
TOTAL BALLAST (LBS.)	830	1080	1380	1705	2055	2655
STATIC ROOF LOAD (LB./FT ²)	8.3	10.8	13.8	17.1	20.6	26.6
ANTENNA & NPMM WT. (LBS.)	430	430	430	430	430	430
NET BALLAST REQUIRED (LBS.)	400	650	950	1275	1625	2225

TABLE 3.0-3 - 1.8M CIRCULAR VSAT ANTENNA
BALLAST REQUIREMENTS - EXPOSURE C - 30 FT. ABOVE GROUND

WIND SPEED (M.P.H.)	70	80	90	100	110	125
TOTAL BALLAST (LBS.)	1155	1505	1905	2355	2830	3680
STATIC ROOF LOAD (LB./FT ²)	11.6	15.1	19.1	23.6	28.3	36.8
ANTENNA & NPMM WT. (LBS.)	430	430	430	430	430	430
NET BALLAST REQUIRED (LBS.)	725	1075	1475	1925	2400	3250

TABLE 3.0-4 - 1.8M CIRCULAR VSAT ANTENNA
BALLAST REQUIREMENTS - EXPOSURE C - 50 FT. ABOVE GROUND

WIND SPEED (M.P.H.)	70	80	90	100	110	125
TOTAL BALLAST (LBS.)	1280	1655	2105	2605	3155	4055
STATIC ROOF LOAD (LB./FT ²)	12.8	16.6	21.1	26.1	31.6	40.6
ANTENNA & NPMM WT. (LBS.)	430	430	430	430	430	430
NET BALLAST REQUIRED (LBS.)	850	1225	1675	2175	2725	3625

METRIC EQUIVALENTS

TABLE 3.0-5 - 1.8M CIRCULAR VSAT ANTENNA
BALLAST REQUIREMENTS - EXPOSURE B - 9M. ABOVE GROUND

WIND SPEED (K.P.H.)	113	129	145	161	177	201
TOTAL BALLAST (LBS.)	342	422	524	649	785	1023
STATIC ROOF LOAD (LB./M ²)	37.0	45.3	56.5	69.7	84.3	110.1
ANTENNA & NPMM WT. (KG.)	195	195	195	195	195	195
NET BALLAST REQUIRED (KG.)	147	227	329	454	590	828

TABLE 3.0-6 - 1.8M CIRCULAR VSAT ANTENNA
BALLAST REQUIREMENTS - EXPOSURE B - 15M ABOVE GROUND

WIND SPEED (K.P.H.)	113	129	145	161	177	201
TOTAL BALLAST (KG.)	376	490	626	773	932	1204
STATIC ROOF LOAD (LB./M ²)	40.4	52.6	67.2	83.3	100.3	129.6
ANTENNA & NPMM WT. (KG.)	195	195	195	195	195	195
NET BALLAST REQUIRED (KG.)	181	295	431	578	737	1009

TABLE 3.0-7 - 1.8M CIRCULAR VSAT ANTENNA
BALLAST REQUIREMENTS - EXPOSURE C - 9M ABOVE GROUND

WIND SPEED (K.P.H.)	113	129	145	161	177	201
TOTAL BALLAST (KG.)	524	683	864	1068	1284	1669
STATIC ROOF LOAD (LB./M ²)	56.5	73.6	93.0	115.0	137.8	179.3
ANTENNA & NPMM WT. (KG.)	195	195	195	195	195	195
NET BALLAST REQUIRED (KG.)	329	488	669	873	1089	1474

TABLE 3.0-8 - 1.8M CIRCULAR VSAT ANTENNA
BALLAST REQUIREMENTS - EXPOSURE C - 15M. ABOVE GROUND

WIND SPEED (K.P.H.)	113	129	145	161	177	201
TOTAL BALLAST (KG.)	581	751	955	1182	1431	1839
STATIC ROOF LOAD (LB./M ²)	62.3	80.9	102.8	127.1	153.9	197.8
ANTENNA & NPMM WT. (KG.)	195	195	195	195	195	195
NET BALLAST REQUIRED (KG.)	386	556	760	987	1236	1644

3.1 BALLAST REQUIREMENT INFORMATION

- 3.1-1. Ballast requirements are provided to assist in determining the applicability of the NPMM for an antenna installation. The ballast data should not be relied upon without competent local professional examination and verification of its accuracy and suitability for a specific site or application.
- 3.1-2. Specific antenna types may require more strength and ballast requirements and must be investigated for each installation. The load carrying requirements of the supporting surface, the mast, the antenna and the antenna's connection to the mast must also be investigated for each installation.
- 3.1-3. Roof pads are recommended to prevent damage to roof membranes. Pads should be placed under all ballast and under the mast pipe. When roof pads are utilized, the minimum coefficient of friction between the ballast pans and roof pad or between the roof pads and the supporting surface must be used to calculate the wind speeds resulting in sliding.
- 3.1-4. When adhesive, sealants or pads are utilized, they must be compatible with the supporting surface. They must also be durable and have adequate strength. Precautions should also be taken to insure that damage to the supporting surface will not occur upon wind loading. Adhesives and sealants must be capable of resisting shear; otherwise, they may act as a lubricant and decrease the effective coefficient of friction between the ballast and the supporting structure.
- 3.1-5. The installation, roof materials and supporting structure must be capable of withstanding all loads imposed by the antenna system. Supporting structure, anchors and/or safety cables must be sufficient to resist the reactions from the antenna system. The installation must meet all applicable, local, state and federal requirements. Due to the many variables involved, Prodelin Corporation does not accept responsibility for verifying the applicability of the NPMM for specific installation.