



Introduction

Comtech EF Data's MBT-4000 Multi-Band RF Transceiver is designed to perform C, X, Ku or Ka RF to L-Band down conversion and L-Band to C, X, Ku or Ka RF up conversion. Additionally, the MBT-4000 provides the following features:

- RF band switching in minimal time without requiring tools
- Minimal cost for a complete system including spares
- Easy expansion for providing a redundant system or other frequency bands
- Rugged construction for mobile and transportable applications
- Automatic band identification for the BUC, BDC, and antenna feed (if the feeds provide an identifying connector)
- Meets or exceeds MIL-STD-188-164A
- Low phase noise
- Auto band sensing capability
- Easy system status verification via LEDs located behind a removable cover
- Flexible configuration:
 - 2 Ups
 - 2 Downs
 - 1 Up and 1 Down

Block Up Converter (BDU-4000)

The BUC-4000 translates the LBC-4000 L-Band output carrier to the desired output frequency (C, X, or Ku) with an output level capable of driving an HPA.

- C-Band: 5850 to 6650 MHz
- X-Band: 7900 to 8400 MHz
- Ku-Band: 13.75 to 14.50 GHz
- Ka-Band: 30.00 to 31.00 GHz (Future)
- No spectral inversion
- 10 dB gain adjustment

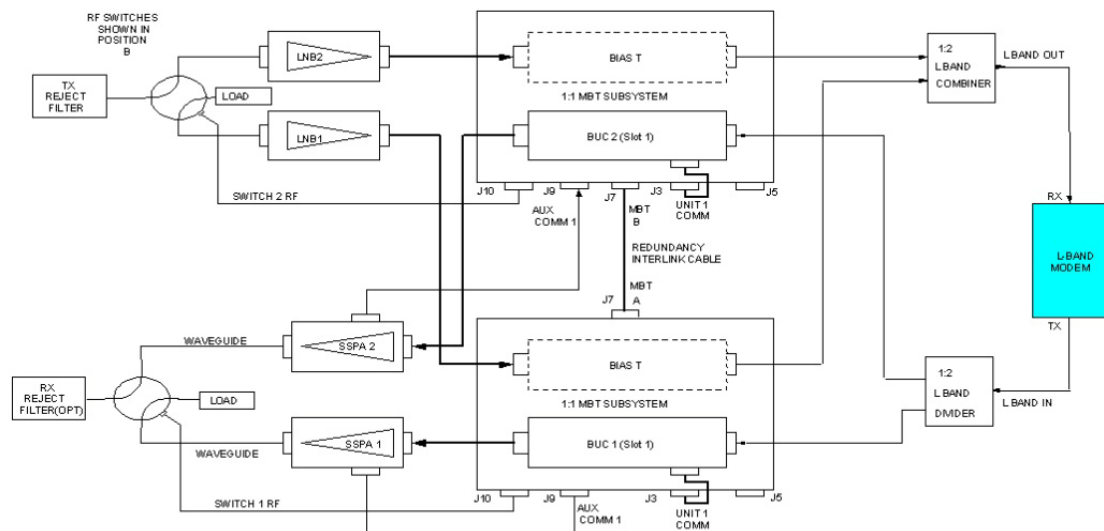

COMTECHEFDATA

DUAL MBT - 4000B REDUNDANT SWITCH

Specifications

BUC-4000 Block Up Converter ODU

Input Frequency Range	950 to 2000 MHz
Output Frequency By Model	
BUC-4000C	5850 – 6650 MHz
BUC-4000X	7900 – 8400 MHz
BUC-4000Ku	13.75 – 14.50 GHz
BUC-4000Ka	30.00 – 31.00 GHz
	27.50 – 28.50 GHz (optional)
	28.50 – 29.50 GHz (optional)
	29.50 – 30.10 GHz (optional)
Input/Output Impedance	50 Ω
Input Return Loss	15 dB minimum
Output Return Loss	18 dB minimum
Input Connector	Type – N, female
Output Connector	N, Female (C-, X-, and Ku-Band)
Gain	15 dB nominal at minimum attenuation (18 dB for Ku-Band BUC)
User Attenuation Range	0 to 10 dB
Output Power, P1dB	+10 dBm minimum
Third Order Intercept	+20 dBm minimum
Carrier Spurious	-60 dBc
Non-Carrier Spurious	-60 dBm

Environmental and Physical

Operating Temperature:	
ODU: BUC-4000	-40° to +50°C (-40° to 122°F)
IDU: LBC-4000	-10° to +50°C (14° to 122 °F)
Operating Humidity	5 to 95 non-condensing
Operating Altitude	10,000 ft above sea level
Non-Operating Temperature:	
ODU: MBT-4000	-50° to +71°C (58° to 160°F)
Prime Power	90 to 260 VAC, 47 to 63 Hz
Size	Refer to the manual
External Reference Input	Either 5 or 10 MHz ± 5 dBm optional
Frequency Stability	1 x 10 ⁻⁹ /day, 1x10 ⁻⁷ /year 40° to +55°C 1 x 10 ⁻⁸ /Temperature

BDC-4000 Block Down Converter ODU

Input Frequency By Model:	
BDC-4000C	3400 to 4200 MHz
BDC-4000X	7250 to 7750 MHz
BDC-4000K	10.95 to 12.75 GHz
BDC-4000Ka	20.20 to 21.20 GHz
	17.70 to 18.70 GHz (optional band)
	18.70 to 19.20 GHz (optional band)
	19.20 to 20.20 GHz (optional band)
Output Frequency Range	950 to 2000 MHz
Input/Output Impedance	50 Ω
Input Return Loss	18 dB minimum
Output Return Loss	15 dB minimum
Input Connector	N, Female (C-, X-, and Ku-Band)
Output Connector	N, Female
Gain	15 dB nominal at minimum attenuation
User Attenuation Range	0 to 10 dB, in 0.25 dB steps (0.1 dB opt)
Output Power, P1dB	+ 12 dBm minimum
Third Order Intercept	+ 22 dBm minimum
Carrier Spurious	-60 dBc
Noise Figure	15 dB max. @ 0 dB attenuation

Typical LNB Characteristics (MBT-4000B)

LNB Input Frequency By Model	
C-Band Input Frequency	3.625 to 4.200 GHz
Noise Figure	≤ 35°K.
Ku-Band Input Frequency Options	
10.95 to 11.70 GHz	
11.70 to 12.20 GHz	
12.25 to 12.75 GHz	
Noise Figure	1.0 dB max.
Output Frequency Range	950 to 2000 MHz (depends on RF band)

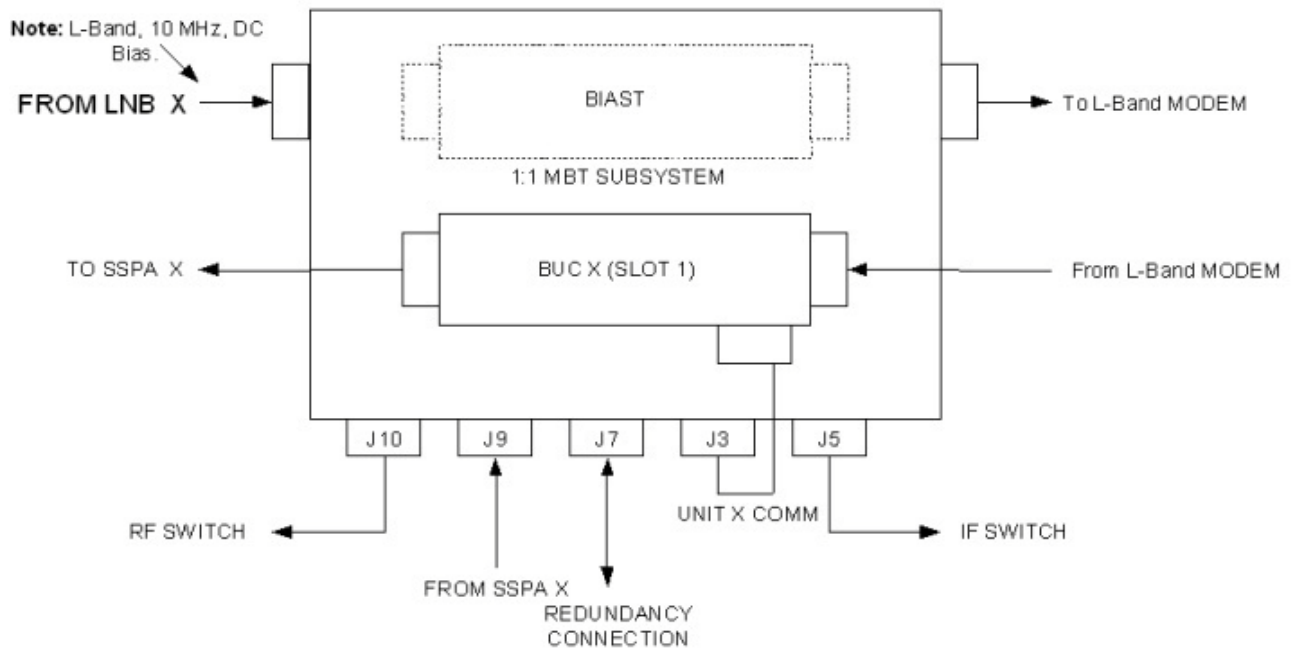

Typical TX/RX Redundant System
(1:2 splitters/combiners may be substituted for the L-Band Input/Output switches)

