

REVISIONS					
REV	ZONE	DESCRIPTION	DATE/ECR	BY	CHK
000-01		ENGINEERING RELEASE	-	-	-
A-02		REVISED AND REDRAWN TO LATEST MODEL GEOMETRY, NOTES AND DIMENSIONS	22-FEB-2010 EC0-341	BS	DH

NO PAINT PERMISSIBLE  
THIS ZONE

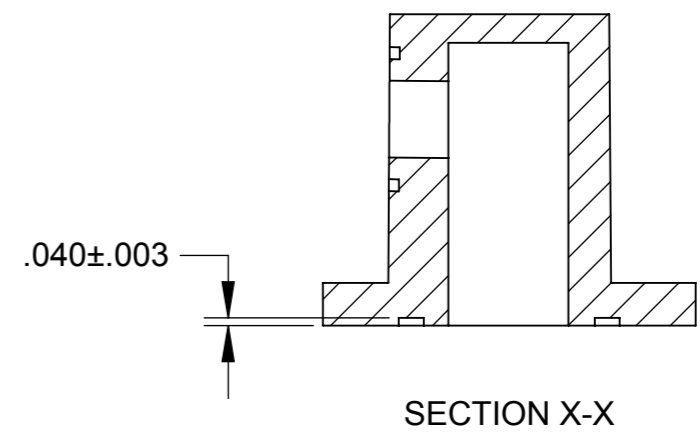

NO PAINT PERMISSIBLE  
THIS SURFACE

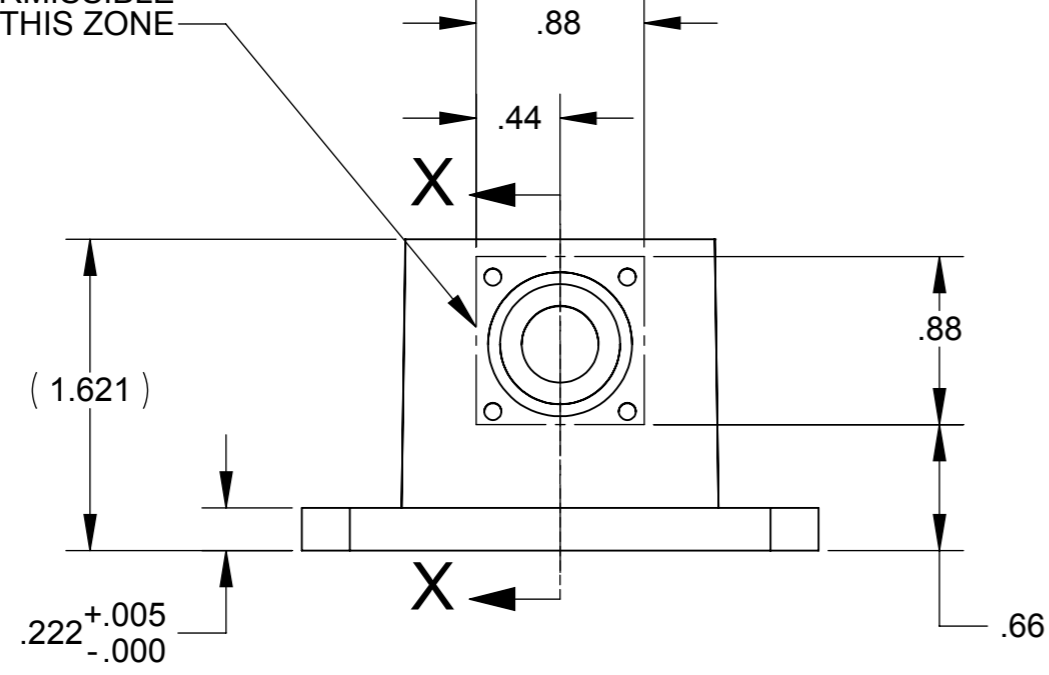
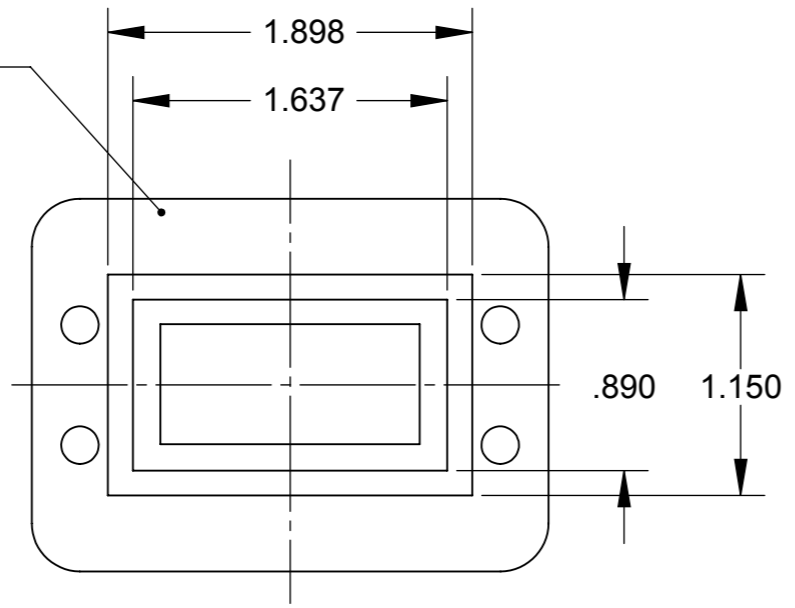

MAKE FROM 1RPE0710  
POWDER COAT GLOSS WHITE PER 00003ES09

SYMBOL KEY	
( X.XX )	REFERENCE DIMENSION
ⓧ.XX	INSPECTION DIMENSION
XX-XX	REVISION CALLOUT
△XX	NOTE CALLOUT

**COBHAM**

DRAWN BY: B.SPRYGADA		CHECKED BY: D.HAMILTON	
DATE DRAWN: 2/22/2010		DATE CHECKED: 2/26/2010	
THIRD ANGLE PROJECTION	DO NOT SCALE	SHEET 1 OF 1	<b>PROPRIETARY AND CONFIDENTIAL</b> THE INFORMATION CONTAINED IN THIS DRAWING IS THE SOLE PROPERTY OF COBHAM. ANY REPRODUCTION IN PART OR AS A WHOLE WITHOUT THE WRITTEN PERMISSION OF COBHAM IS PROHIBITED.
DIMENSIONS ARE IN INCHES		SHEET SIZE A3	
UNLESS OTHERWISE SPECIFIED: FRACTIONAL ± 1/8 ONE PLACE X.X ± .06 TWO PLACE X.XX ± .02 THREE PLACE X.XXX ± .005 ANGLES: ± 1° DIMENSIONS TO THEORETICAL SHARP CORNERS DIMENSION PER ASME Y14.5-2009		DESCRIPTION <b>ADAPTOR, MACHINED, WR137 TO N</b>	
		PART NUMBER	PRODUCT REVISION
		<b>2ETXADP-WR137-N</b>	<b>A</b>