



**Advantech
Wireless**



SapphireBlu™ Class GaN Technology

**1,250W Ku-Band Hubmount
UltraLinear™ SSPA/ SSPB**

SSPA **AWMAg-K** **5200-SapphireBlu™ series**
SSPB (BUC) **SSPBMg-K** **5200-SapphireBlu™ series**



- High power density in a compact, rugged, weatherproof package
- UltraLinear™, designed for Multi Carrier Operations
- High Performance GaN Technology SSPA Outdoor design concept
- High Reliability, High Linearity, Low Energy Consumption

THE ULTIMATE SOLUTION FOR DIRECT TO HOME TV

Save 8 to 10 dB power compared to Indoor Klystron
 Save Millions of dollars in Energy Cost, Satellite Bandwidth, CAPEX
 Can cover multiple transponders, full DVB-S2 enabled
 Rugged, Weatherproof Outdoor Package, MIL-STD-188-164A Compliant
 Redundant Ready, Power Expandable to 3 KW by phase combining

- ⇒ Exceeds all barriers between Klystrons, TWTs and SSPAs
- ⇒ We can now saturate all transponders of an entire satellite and obtain maximum bandwidth/power efficiency! (using modular RF concept)
- ⇒ 3 years warranty, due to increased GaN Technology reliability
- ⇒ Backed by over 25 years of Outdoor SSPA design and manufacturing.

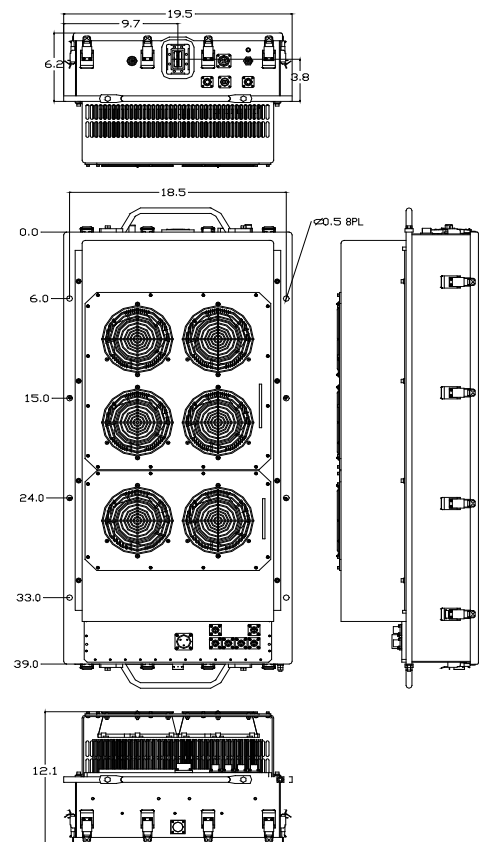

Please call or visit our site for more information >>>

www.AdvantechWireless.com

Specifications	KS / KX	
Operating Frequency	14.0 – 14.5 GHz / 13.75 – 14.5 GHz	
L-Band input (BUC)	950 – 1450 MHz / 950 – 1700 MHz	
Output Power	1250W	
PSAT, PA Module	+60.7 dBm nominal	
P _{SAT} , at Flange	+58 dBm nominal	
PLINEAR	+56.0 dBm minimum	
	P _{LINEAR} is the power at which the IMD specs are met and the spectral regrowth is <-30 dBc @ 1.0 x symbol rate for QPSK/OQPSK/8PSK modulation QPSK/OQPSK/8PSK modulation	
Gain SSPA	68 ± 3 dB	
SSPB (BUC)	78 ± 3 dB	
Gain adjustment range	20 dB in 1.0 dB steps	
Gain flatness over full band	SSPA 2dB p-p max SSPB (BUC) 4 dB p-p max (KS); 4dB p-p (KX)	
Gain slope over 40 MHz	± 0.3 dB max SSPB (BUC) ± 0.5 dB max	
Gain variation over temperature	± 1.5 dB max	
Input Impedance and VSWR	50 Ω SSPA 1.3:1 SSPB (BUC) 1.4:1	
Output VSWR	1.3:1	
Noise power density	-70 dBm/Hz in Transmit Band, -145 dBm/Hz in Receive Band (10.95 GHz – 12.75 GHz)	
Spurious at P _{LINEAR}	SSPA: -65 dBc max SSPB (BUC): -55 dBc max	
Harmonics	-50 dBc @ P _{LINEAR}	
AM/PM conversion	<1.0°/dB P _{LINEAR}	
Third order intermod (two tones)	-25 dBc two signals 5 MHz apart at total +56 dBm Plinear	
Group delay	Ripple 1 nsec p-p max over any 40 MHz band	
Residual AM Noise	0 – 10 kHz -45 dBc	
	10 kHz – 500 kHz -20 (1.25 + log F) dBc F = Frequency in kHz	
	500 kHz – 1 MHz -80 dBc	
SSPB (BUC)		
Local Oscillator freq.	13.05 GHz	12.8 GHz
Internal Reference frequency (optional)	10 MHz	
	Aging/day	±2 ⁻¹⁰
	Aging/year	±5 ⁻⁸
	Stability	±2 ⁻⁸ over temp range
Phase Noise	-53 dBc/Hz at 10Hz	
	-63 dBc/Hz at 100Hz	
	-73 dBc/Hz at 1000Hz	
External Reference Frequency phase noise (max)	10 MHz	
	-120 dBc/Hz at 10Hz	
	-135 dBc/Hz at 100Hz	
	-150 dBc/Hz at 1000Hz	
Weight & Dimensions		
Dimensions	L x W x H 39.00" x 18.50" x 12.10" (990 x 470 x 307 mm)	
Weight	176 lbs (80 kg)	
AC input voltage	190 – 265 VAC (47-63 Hz)	
Power consumption	3.5kW at 53 dBm 5kW at P _{LINEAR} 7.0kW at P _{SAT}	
Interfaces	Input (RF or L-Band) - N type female AC line - MS3102 type	
	Output Sample Port - N type female RF output - WR75 Cover	
	RS485/Ethernet MS3112 type	
Environmental	Temperature	Operating -30°C to +55 °C Option 1 -40°C to +55 °C Option 2 -50°C to +50 °C
		Storage -55°C to +85 °C
	Humidity	100% condensing
	Altitude	10,000' AMSL, derated by 2 °C/1000' from AMSL

NORTH AMERICA
USA
Tel: +1 703 659 9796
Fax: +1 703 635 2212
info.usa@advantechwireless.com

CANADA
Tel: +1 514 420 0045
Fax: +1 514 420 0073
info.canada@advantechwireless.com

EUROPE
UNITED KINGDOM
Tel: +44 1480 357 600
Fax: +44 1480 357 601
info.uk@advantechwireless.com

RUSSIA & CIS
Tel: +7 495 971 59 18
info.russia@advantechwireless.com

INDIA
Tel: +91 33 2415 5922
info.india@advantechwireless.com

SOUTH AMERICA
Tel: +1 514 420 0045
Fax: +1 514 420 0073
info.latam@advantechwireless.com

BRAZIL
Tel: +55 11 3054 5701
Fax: +55 11 3054 5701
info.brazil@advantechwireless.com

An ISO 9001: 2008 Company



Ref.: PB-SAPPH-Ku-1250-14119